



Fitting Instructions – VPLDT0085

Land Rover Defender 110 – 1998 onwards – TD5 only

MATERIALS

A	1	Towbar Centre Plate with European facing to 94/20/EC A50-1
A1	1	Cross Bar
C	2	Side Arms
D	3	M10 x 25 x 1.5mm Bolts, Lock Washers and Flat Washers (20mm O.D.)
E	2	M16 x 40 x 2.0mm Bolts and Lock Washers
F	2	M12 x 30 x 1.75mm Bolts and Nyloc Nuts
H	2	M16 x 50 x 2.0mm Bolts, Nuts and Lock Washers
I	1	ZEP35 Electrical plate (not shown)
CB	2	M16 x 65 x 2.0mm Coupling Bolts, Nuts and Lock Washers
CP	1	10mm Coupling Packer

FITTING

1. Loosely attach Cross Bar (A1) to underside of rear cross member using Bolts (D). Loosely attach Centre Plate (A) to rear cross member using Bolts (E).
2. Attach Centre Plate (A) to Cross Bar (A1) using Bolts (F). Attach Side Arms (C) to Centre Plate (A) using Bolts (H).
3. Remove towing eyes and attach Side Arms (C) to chassis using original bolts, re-fitting towing eyes at the same time. Tighten all bolts.

NOTE: This towbar is EC type approved to be used with either a Witter Towball (part number Z11) or a Class A50-X towball with a 'D' Value greater than or equal to that of the towbar. These towballs can also be used in conjunction with drop-plates giving a ball height reduction of up to 75mm or coupling spacers of up to 50mm.

This towbar is also EC type approved for use with Witter combination 'Pin & Ball' units our part no. Z32 (Dixon Bate part no. 202014) or Z6 (Bradley part no. U352L) as well as the new Bradley heavy duty ball and autojaw (Bradley part no. AJ352L).

Please refer to the vehicle specification for the trailer weight and nose limits, which must be observed.

Recommended torque settings: M8 - 27Nm, M10 - 53 Nm, M12 - 95 Nm, M14 - 150 Nm, M16 - 214 Nm

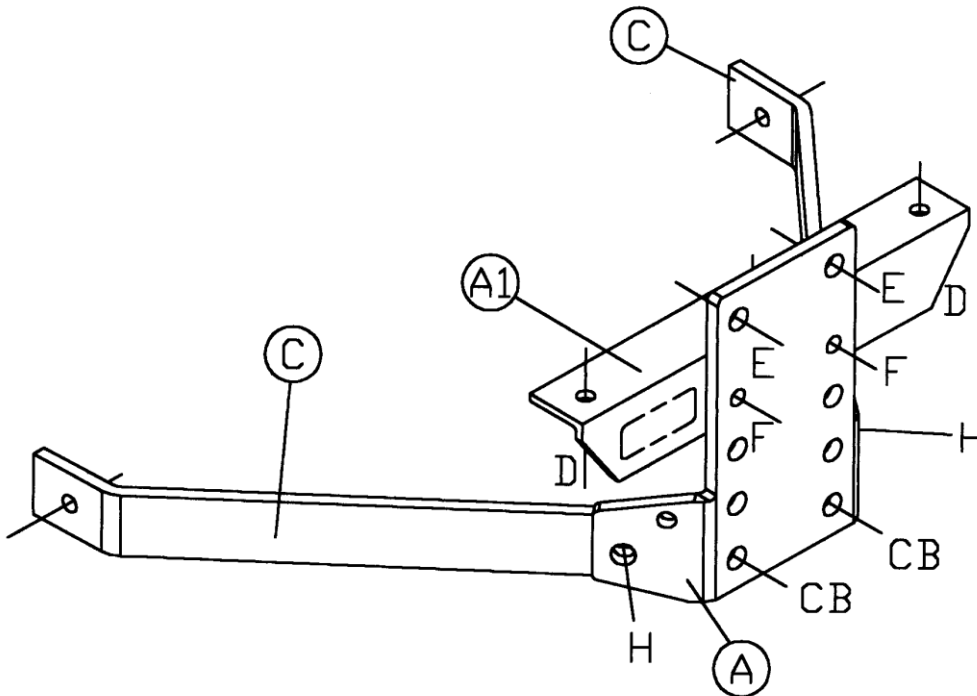

μW0001R29A-FIT\$0108022200000ÄÄ

W 0001R29A-FIT\$010802220000