

TerrafirMa
Serious 4x4 Accessories

TFFR01 MANUAL



**PORTABLE 12/24 VOLTS DC
REFRIGERATOR / FREEZER**

www.terrafirma4x4.com

Safety Awareness

Read this manual carefully and understand the contents before you install the refrigerator / freezer.

Be aware of possible safety hazards when you see the safety alert symbol on the refrigerator / freezer and in this manual. A signal word follows the safety alert symbol and identifies the danger of the hazard. Carefully read the descriptions of these signal words to fully know their meanings. They are for your safety.



WARNING: This signal word means a hazard, which if ignored, can cause dangerous personal injury, death, or much property damage.

CAUTION: This signal word means a hazard, which if ignored, can cause small personal injury or much property damage.

Model No. and Serial No.

The model number and serial number are on a label which is on the bottom of the refrigerator / freezer.

General

This portable refrigerator / freezer is to be used in vehicles such your car, boat, trailer, or camper for the refrigerated or frozen storage of food, drinks, medicines, etc.

The refrigerator / freezer should be placed on a level and solid surface. The compressor has shock mounts to allow the refrigerator / freezer operation during transit.

Be sure the refrigerator / freezer is not in direct sunlight or near a gas stove, a heater, or other heat-generating appliances. Avoid placing your refrigerator / freezer in an area where it could be accidentally splashed or sprayed with water which could enter the electrical compartment of the refrigerator / freezer.

Your refrigerator / freezer was thoroughly cleaned before shipment from the factory. It is advisable, however, to clean the interior once more before using. Wipe the interior with a cloth and warm water. Then wipe with a dry cloth.

Operation

The battery voltage varies with the type of vehicle. Most cars and boats use a 12 volt system. A 12/24 volt battery with a negative ground is necessary to operate the refrigerator / freezer. This refrigerator / freezer operates on 12/24 volts DC from a battery in your car, boat, trailer, camper, etc. The refrigerator / freezer circuitry identifies the operating voltage. The refrigerator / freezer will operate in ambient temperatures of between 14°F (-10°C) and 109°F (43°C) and in a maximum relative humidity of 90%. The refrigerator / freezer will also operate continuously at a maximum angle of 20° off of level.

WARNING: Never store combustible materials near the refrigerator / freezer. Storing combustible materials near the refrigerator / freezer creates a safety hazard and also decreases the ventilation of the cooling system which decreases the refrigerator / freezer performance.



CAUTION: Do not touch the liner or other metal parts inside the refrigerator / freezer cabinet with wet hands because they can freeze to the refrigerator / freezer.

WARNING: Always disconnect all power sources from the refrigerator / freezer when doing routine maintenance. Have service work done only by a qualified service technician.

Start the Refrigerator / freezer

1. Put the square plug end of the DC power cord into the DC connector of the refrigerator / freezer (see diagram).
2. Put the cigarette lighter plug end of the DC power cord into the cigarette lighter of the vehicle.
3. Put the power switch in the "ON" position.
4. Put the Low Battery Shut-off Switch in the desired position. - Position 3 is the recommended position.
5. When using the AC/DC converter to operate the refrigerator / freezer, make sure that the Low Battery Shut-off Switch is in either position 1 or 3.- The refrigerator / freezer will NOT operate if Low Battery Shut-off Switch is in position 2.

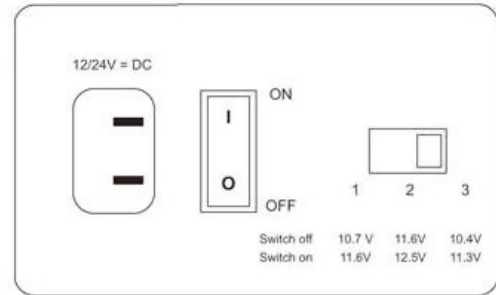

| Low Battery Shut-off Switch | 12 VDC | 24 VDC |
|-----------------------------|---------------------------------------|---------------------------------------|
| 1 | off voltage 10.7V - on voltage 11.6V | off voltage 22.6V - on voltage 24.0V |
| 2 | off voltage 11 .6V - on voltage 12.5V | off voltage 24.2V - on voltage 25.2V |
| 3 | off voltage 10.4V - on voltage 11.3V | off voltage 21 .8V - on voltage 23.2V |

Set the Temperature

The Temperature Setting Panel has two modes of operation, the Factory setting mode and the Memory setting mode. In both modes, you may set the controls to maintain the temperature, in the center part of the refrigerator / freezer, between -13°F (-25°C) and 108°F (42°C).

Push and hold both the up arrow and the "set" button for a few seconds to change the temperature display back and forth between Fahrenheit (°F) and Celsius (°C).

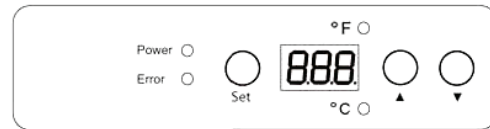

Factory setting mode

Each time that you turn the refrigerator / freezer "ON", the temperature setting is 5°F (-15°C). If you wish to change the temperature setting:

- Press and hold the "Set" button for 2 seconds.
- Press and hold either the up or down arrow until the desired temperature appears in the window.
- Release the up or down arrow to select the temperature setting.

Memory setting mode

The first time that you turn the refrigerator / freezer "ON", the temperature setting is 5°F (-15°C). If you wish to change the temperature setting:

- Press and hold the "set" button for 2 seconds.
- Press and hold either the up or down arrow until the desired temperature appears in the window.
- Release the up or down arrow to select the temperature setting.
- Press and hold the "set" button for 2 seconds.
- The next time that you turn the refrigerator / freezer "ON", the temperature setting will be at this same setting, unless you choose to change it.

NOTE: The refrigerator / freezer has a delay protection feature to avoid overloading the vehicle at start-up. The temperature shown in the window should change within the first 15 minutes of operation.

When not using the refrigerator / freezer, remove the DC power cord from the cigarette lighter to prevent discharge of the battery.

Over cooling drains your vehicle battery

When the ambient temperature is between 70°F (21°C) and 90°F, (32°C) keep the temperature setting at about 40°F (4°C) to avoid an excessive drain of the battery. When making ice, or storing frozen foods, change the temperature setting to about 25°F (-4°C).

Check the Battery Charge Level

If the DC voltage to the refrigerator / freezer is less than 10.7 volts, the cooling performance of the refrigerator / freezer will immediately decrease. Make sure that the battery is fully charged.

A fully charged battery will have a specific gravity reading of between 1.260 and 1.280. The battery voltage is best indicated when the refrigerator / freezer is "ON" and the battery charging system is "OFF". Charge the battery when the specific gravity reading is less than 1.200.

NOTE: Never use a battery charger or a rectifier, etc. instead of the cigarette light adapter to operate the refrigerator / freezer on DC power. These electrical devices cause high ripples or surge voltages which can damage the refrigerator / freezer.

Never use a commercial inverter or converter to operate the refrigerator / freezer on AC power. These electrical devices do not hold the constant frequency that is necessary for the refrigerator / freezer.

Only use a "quick charger" on the vehicle battery if the power switch is tuned to "OFF". If a "quick charger" is used on the battery while the power switch is "ON", damage to the refrigerator / freezer can occur.

Cooling Unit Basics

The cooling unit of your Terrafirma refrigerator / freezer makes heat. This heat must be removed quickly and efficiently in order for the refrigerator / freezer to have its maximum cooling performance. When the refrigerator / freezer is in an enclosed space, the temperature within the space will rise quickly and will reduce the cooling performance of the refrigerator / freezer. Continued operation at high temperatures can damage the refrigerator / freezer compressor and other components.

A free flow of air (ventilation) through the refrigerator / freezer condenser coils and around the compressor is necessary for the refrigerator / freezer to operate correctly. While Terrafirma refrigerator / freezers are made to operate in more severe conditions than typical household refrigerator / freezers, you should not operate the refrigerator / freezer in high ambient temperatures. This will result in poor performance and possible food spoilage.

Convection Basics

When ventilating an enclosed space, consider the facts of natural convection, that cool air falls and warm air rises. The ideal ventilation design will use natural convection and provide a path for cool air to enter below the refrigerator / freezer and warmer air to exit above the refrigerator / freezer. The design of the refrigerator / freezer allows this to occur if there is a ventilation opening above the refrigerator / freezer. The heat created by the refrigerator / freezer can then flow freely out of the enclosed space rather than be trapped within it.

Ventilation for TerraFirma Portable Refrigerator / Freezers

For the maximum cooling efficiency and the lowest power consumption, use the following guidelines. These are especially important when using the refrigerator / freezer under a counter or in an enclosed space.

- Make sure that there are at least 4 inches (102 mm) of clearance [10] from the vents on each side of the compressor compartment.
- When using the refrigerator / freezer in an enclosed space such as an RV basement, make sure that there are at least 48 square inches (310 square cm) of ventilation area above the compressor compartment. Less than 48 square inches (310 square cm) of ventilation area will result in poor refrigeration performance, continuous compressor operation, and a shortened refrigerator / freezer life.
- The ventilation area should open into the living area of the vehicle

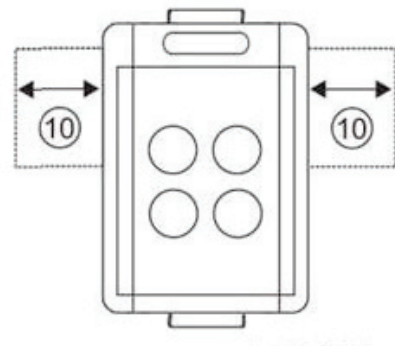

Storage

When storing portable refrigerator / freezers, make sure that there are no obstructions (luggage, etc.) around the refrigerator / freezer while it is operating.

Make sure that there is adequate ventilation space to the refrigerator / freezer. Locate the ventilation space in an area that allows natural convection through the refrigerator / freezer condenser coils and around the compressor.

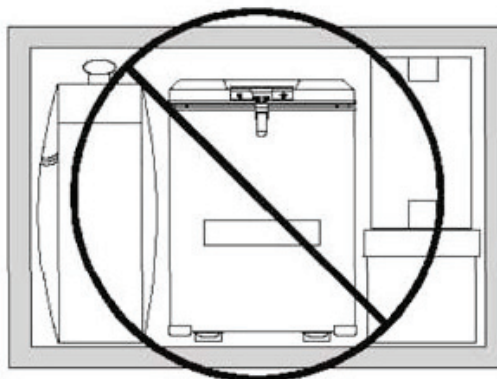

Storing Food

Store fresh foods in covered dishes, in plastic bags, in foil wrap, etc. to prevent them from becoming dry and from transferring odors to other stored foods.

Store frozen food for several days if it stays fully frozen. If frozen food is allowed to thaw, DO NOT attempt to refreeze it. Since liquids expand as they freeze, do not freeze liquids in glass containers as this may cause the glass container to break.

Defrosting

It is normal for frost to collect on the liner inside the refrigerator / freezer. Excess frost decreases the cooling performance of the refrigerator / freezer. Defrost the refrigerator / freezer as necessary.

CAUTION: Do not use sharp objects, a hair dryer, a heat gun, etc. to defrost the refrigerator / freezer. Damage to the interior of the refrigerator / freezer can occur.



- Turn the power switch to the “OFF” position.
- Remove all food from the refrigerator / freezer.
- Put dry towels (etc.) inside the refrigerator / freezer to absorb the excess water.
- Remove the wet towels (etc.) and dry the inside of the refrigerator / freezer.
- Restart the refrigerator / freezer and set the temperature.
- Put the food in the refrigerator / freezer.

Cleaning

A good time to clean the refrigerator / freezer is just after you defrost it. Clean the inside of the refrigerator / freezer as often as necessary to avoid food odors:

- Remove all food from the refrigerator / freezer.

NOTE: Do not use abrasive cleaners, chemicals, or scouring pads because they can damage the inside of the refrigerator / freezer.

- Wash the inside of the refrigerator / freezer and the door gasket with a solution of liquid dish detergent and warm water.
- Rinse with clean water and dry.

Troubleshooting

| Indicator Lights | Problem | Solution |
|--|--|--|
| Power light is on. Error light is off. | No problems. | Normal operating condition. |
| Power light is off. Error light is on. | The refrigerator/ freezer has no power | Check the 10 Amp glass that is located in the cigarette lighter plug body of the power cord |
| Power light is on. Error light flashes once | The voltage is wrong | Turn the refrigerator / freezer "OFF", or choose the voltage setting again, or the voltage to the refrigerator / freezer is low. * When using the AC/DC converter to operate the refrigerator / freezer, make sure that the Low Battery Shut-off Switch is in either position 1 or 3. |
| Power light is on. Error light flashes twice | The current is wrong (or fan current is wrong) | Check the fan |
| Power light is on. Error light flashes 3 times | Fan speed is wrong | Ambient temperature is more that the normal operating temperature,or the refrigerator / freezer air-intake vent is obstructed. |
| Power light is on. Error light flashes continuously | The temperature is wrong. | Ambient temperature is more than the normal operating temperature, or the refrigerator / freezer air-intake vent is obstructed. |

Refrigerator / Freezer Specification

Terrafirma Part Number: TFFR01

| | |
|----------------------------------|--|
| Capacity (gross) | 11.8 Gal (45 l) |
| Dimensions (H x L x W) | 16.9 in (430mm) x 25.5 in (650mm) x 15.7 in (400mm) |
| Voltage | 12/24 VDC @ ≤5.0 A ±10% |
| Average Power Consumption | ≤50W + 15% |
| Temperature Range | 46°F (8°C) to ≥ 0°F(-18°C) * Variable by electronic thermostat |
| Weight | Net: 44.0 lb (20kg) |
| Refrigerant | R134A |
| Refrigeration Capacity | Temperature of 3.2°F (-16°C) in 2 hours (under the standard runningcondition and rated load) |
| Other Features | Digitaltemperature control panel. Compressor torque and fanspeed adjust automatically. |

Wiring Diagram

- 1.....Operation and control board
- 2.....Compressor
- 3.....Compressor control unit
- 4.....Temperature sensor
- 5.....Switch
- 6.....Low voltage shut-off
- 7.....Fan

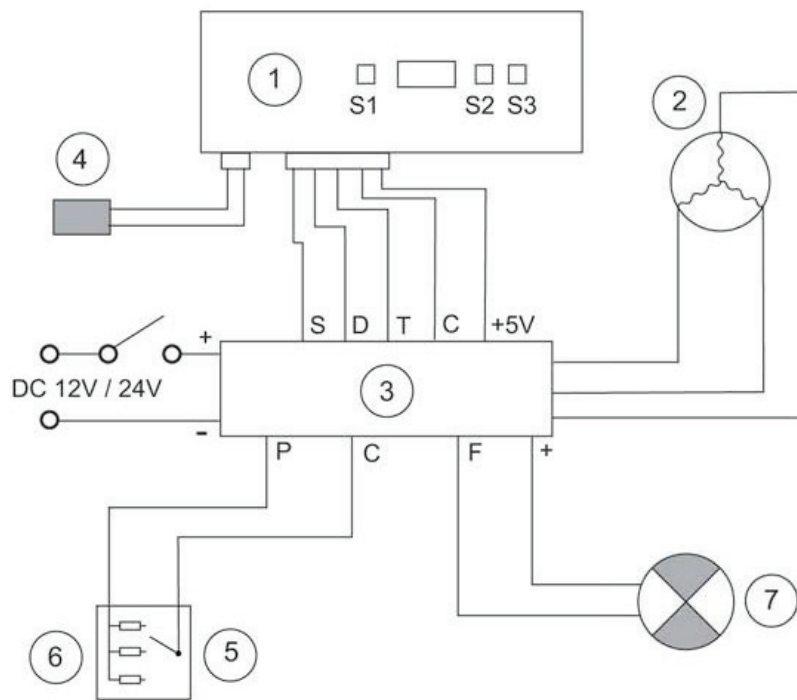

TFFR02



TFFR03

TFFR01 MANUAL